



RF Power Field Effect Transistors

N-Channel Enhancement-Mode Lateral MOSFETs

Designed primarily for pulsed wideband applications with frequencies up to 500 MHz. Devices are unmatched and are suitable for use in industrial, medical and scientific applications.

- Typical Pulsed Performance at 450 MHz: $V_{DD} = 50$ Volts, $I_{DQ} = 150$ mA, $P_{out} = 1000$ Watts Peak (200 W Avg.), Pulse Width = 100 μ sec, Duty Cycle = 20%
 Power Gain — 20 dB
 Drain Efficiency — 64%
- Capable of Handling 10:1 VSWR, @ 50 Vdc, 450 MHz, 1000 Watts Peak Power

Features

- Characterized with Series Equivalent Large-Signal Impedance Parameters
- CW Operation Capability with Adequate Cooling
- Qualified Up to a Maximum of 50 V_{DD} Operation
- Integrated ESD Protection
- Designed for Push-Pull Operation
- Greater Negative Gate-Source Voltage Range for Improved Class C Operation
- RoHS Compliant
- In Tape and Reel. R6 Suffix = 150 Units per 56 mm, 13 inch Reel.

MRF6VP41KHR6
MRF6VP41KHSR6

10-500 MHz, 1000 W, 50 V
LATERAL N-CHANNEL
BROADBAND
RF POWER MOSFETs

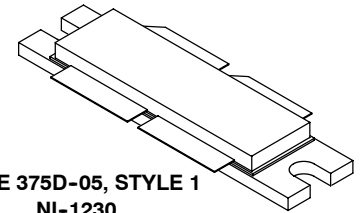

CASE 375D-05, STYLE 1
NI-1230
MRF6VP41KHR6

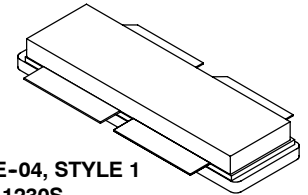

CASE 375E-04, STYLE 1
NI-1230S
MRF6VP41KHSR6

PARTS ARE PUSH-PULL

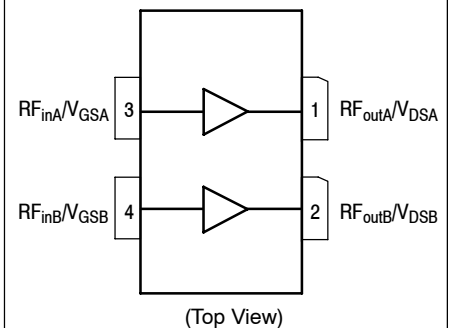

Figure 1. Pin Connections

Table 1. Maximum Ratings

Rating	Symbol	Value	Unit
Drain-Source Voltage	V_{DSS}	-0.5, +110	Vdc
Gate-Source Voltage	V_{GS}	-6, +10	Vdc
Storage Temperature Range	T_{stg}	-65 to +150	$^{\circ}$ C
Case Operating Temperature	T_C	150	$^{\circ}$ C
Operating Junction Temperature (1,2)	T_J	225	$^{\circ}$ C
CW Operation @ $T_C = 25^{\circ}$ C Derate above 25 $^{\circ}$ C	CW	1107 4.6	W W/ $^{\circ}$ C

1. Continuous use at maximum temperature will affect MTTF.
2. MTTF calculator available at <http://www.freescale.com/rtf>. Select Software & Tools/Development Tools/Calculators to access MTTF calculators by product.

Table 2. Thermal Characteristics

Characteristic	Symbol	Value (1,2)	Unit
Thermal Resistance, Junction to Case Case Temperature 80°C, 1000 W Pulsed, 100 μsec Pulse Width, 20% Duty Cycle, 450 MHz Case Temperature 48°C, 1000 W CW, 352.2 MHz	R _{θJC}	0.03 0.15	°C/W

Table 3. ESD Protection Characteristics

Test Methodology	Class
Human Body Model (per JESD22-A114)	2 (Minimum)
Machine Model (per EIA/JESD22-A115)	A (Minimum)
Charge Device Model (per JESD22-C101)	IV (Minimum)

Table 4. Electrical Characteristics (T_A = 25°C unless otherwise noted)

Characteristic	Symbol	Min	Typ	Max	Unit
----------------	--------	-----	-----	-----	------

Off Characteristics ⁽³⁾

Gate-Source Leakage Current (V _{GS} = 5 Vdc, V _{DS} = 0 Vdc)	I _{GSS}	—	—	10	μAdc
Drain-Source Breakdown Voltage (I _D = 300 mA, V _{GS} = 0 Vdc)	V _{(BR)DSS}	110	—	—	Vdc
Zero Gate Voltage Drain Leakage Current (V _{DS} = 50 Vdc, V _{GS} = 0 Vdc)	I _{DSS}	—	—	100	μAdc
Zero Gate Voltage Drain Leakage Current (V _{DS} = 100 Vdc, V _{GS} = 0 Vdc)	I _{DSS}	—	—	5	mA

On Characteristics

Gate Threshold Voltage ⁽³⁾ (V _{DS} = 10 Vdc, I _D = 1600 μAdc)	V _{GS(th)}	1	1.68	3	Vdc
Gate Quiescent Voltage ⁽⁴⁾ (V _{DD} = 50 Vdc, I _D = 150 mAdc, Measured in Functional Test)	V _{GS(Q)}	1.5	2.2	3.5	Vdc
Drain-Source On-Voltage ⁽³⁾ (V _{GS} = 10 Vdc, I _D = 4 Adc)	V _{DS(on)}	—	0.28	—	Vdc

Dynamic Characteristics ⁽³⁾

Reverse Transfer Capacitance (V _{DS} = 50 Vdc ± 30 mV(rms)ac @ 1 MHz, V _{GS} = 0 Vdc)	C _{rss}	—	3.3	—	pF
Output Capacitance (V _{DS} = 50 Vdc ± 30 mV(rms)ac @ 1 MHz, V _{GS} = 0 Vdc)	C _{oss}	—	147	—	pF
Input Capacitance (V _{DS} = 50 Vdc, V _{GS} = 0 Vdc ± 30 mV(rms)ac @ 1 MHz)	C _{iss}	—	506	—	pF

Functional Tests ⁽⁴⁾ (In Freescale Test Fixture, 50 ohm system) V_{DD} = 50 Vdc, I_{DQ} = 150 mA, P_{out} = 1000 W Peak (200 W Avg.), f = 450 MHz, 100 μsec Pulse Width, 20% Duty Cycle

Power Gain	G _{ps}	19	20	22	dB
Drain Efficiency	η _D	60	64	—	%
Input Return Loss	IRL	—	-18	-9	dB

1. MTTF calculator available at <http://www.freescale.com/rf>. Select Software & Tools/Development Tools/Calculators to access MTTF calculators by product.
2. Refer to AN1955, *Thermal Measurement Methodology of RF Power Amplifiers*. Go to <http://www.freescale.com/rf>. Select Documentation/Application Notes - AN1955.
3. Each side of device measured separately.
4. Measurement made with device in push-pull configuration.

(continued)

Table 4. Electrical Characteristics ($T_A = 25^\circ\text{C}$ unless otherwise noted) (continued)

Characteristic	Symbol	Min	Typ	Max	Unit
Typical Performance — 352.2 MHz (In Freescale 352.2 MHz Test Fixture, 50 ohm system) $V_{DD} = 50\text{ Vdc}$, $I_{DQ} = 150\text{ mA}$, $P_{out} = 1000\text{ W CW}$					
Power Gain	G_{ps}	—	20.1	—	dB
Drain Efficiency	η_D	—	67	—	%
Input Return Loss	IRL	—	-10.2	—	dB
Typical Performance — 500 MHz (In Freescale 500 MHz Test Fixture, 50 ohm system) $V_{DD} = 50\text{ Vdc}$, $I_{DQ} = 150\text{ mA}$, $P_{out} = 1000\text{ W Peak}$ (200 W Avg.), $f = 500\text{ MHz}$, 100 μsec Pulse Width, 20% Duty Cycle					
Power Gain	G_{ps}	—	19.5	—	dB
Drain Efficiency	η_D	—	66	—	%
Input Return Loss	IRL	—	-23	—	dB

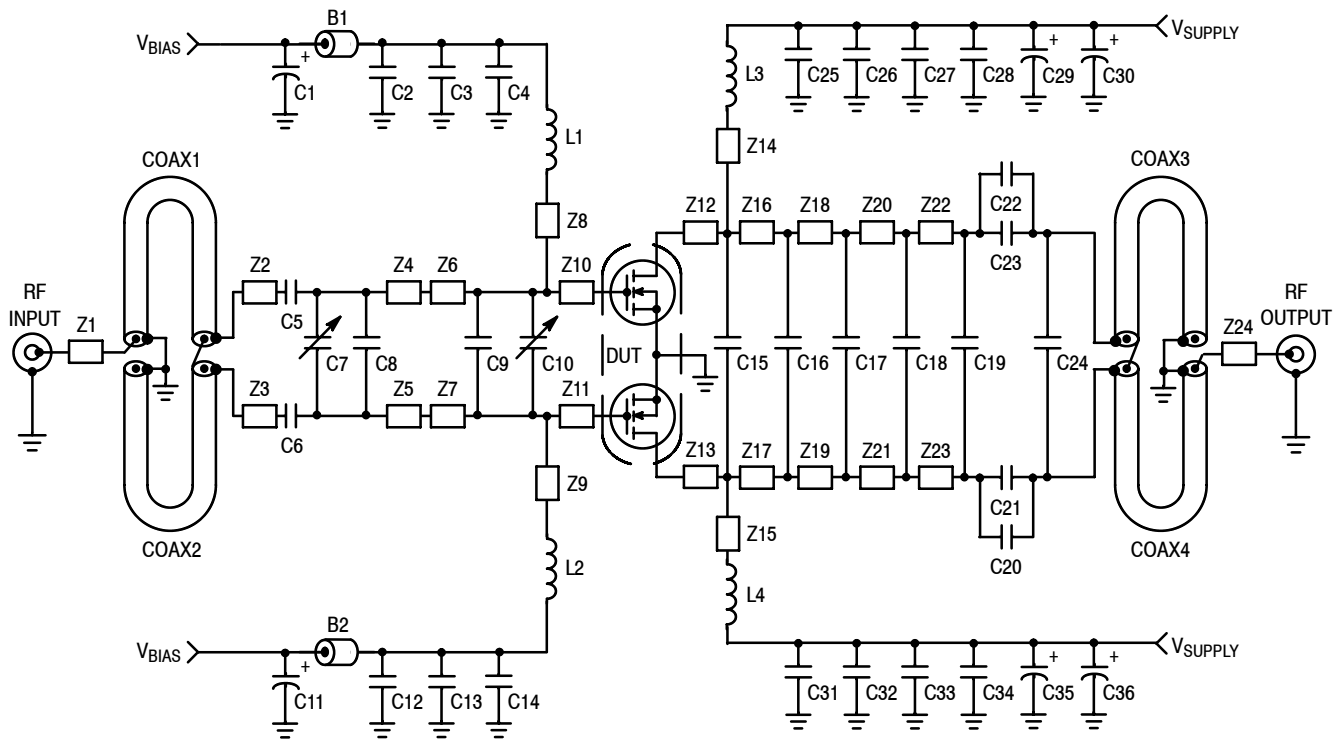

Z1	0.366" x 0.082" Microstrip	Z14*, Z15*	0.764" x 0.150" Microstrip
Z2*, Z3*	0.170" x 0.100" Microstrip	Z16, Z17	0.290" x 0.430" Microstrip
Z4*, Z5*	0.220" x 0.451" Microstrip	Z18, Z19	0.100" x 0.430" Microstrip
Z6, Z7	0.117" x 0.726" Microstrip	Z20, Z21, Z22, Z23	0.080" x 0.430" Microstrip
Z8*, Z9*	0.792" x 0.058" Microstrip	Z24	0.257" x 0.215" Microstrip
Z10, Z11	0.316" x 0.726" Microstrip	PCB	Arlon CuClad 250GX-0300-55-22, 0.030", $\epsilon_r = 2.55$
Z12, Z13	0.262" x 0.507" Microstrip		

* Line length includes microstrip bends

Figure 2. MRF6VP41KHR6(HSR6) Test Circuit Schematic — 450 MHz

Table 5. MRF6VP41KHR6(HSR6) Test Circuit Component Designations and Values — 450 MHz

Part	Description	Part Number	Manufacturer
B1, B2	47 Ω , 100 MHz Short Ferrite Beads	2743019447	Fair-Rite
C1, C11	47 μ F, 50 V Electrolytic Capacitors	476KXM063M	Illinois
C2, C12, C28, C34	0.1 μ F Chip Capacitors	CDR33BX104AKYS	Kemet
C3, C13, C27, C33	220 nF, 50 V Chip Capacitors	C1812C224K5RAC	Kemet
C4, C14	2.2 μ F, 50 V Chip Capacitors	C1825C225J5RAC	Kemet
C5, C6, C8, C15	27 pF Chip Capacitors	ATC100B270JT500XT	ATC
C7, C10	0.8–8.0 pF Variable Capacitors	27291SL	Johanson Components
C9	33 pF Chip Capacitor	ATC100B330JT500XT	ATC
C16	12 pF Chip Capacitor	ATC100B120JT500XT	ATC
C17	10 pF Chip Capacitor	ATC100B100JT500XT	ATC
C18	9.1 pF Chip Capacitor	ATC100B9R1CT500XT	ATC
C19	8.2 pF Chip Capacitor	ATC100B8R2CT500XT	ATC
C20, C21, C22, C23, C25, C32	240 pF Chip Capacitors	ATC100B241JT200XT	ATC
C24	5.6 pF Chip Capacitor	ATC100B5R6CT500XT	ATC
C26, C31	2.2 μ F, 100 V Chip Capacitors	2225X7R225KT3AB	ATC
C29, C30, C35, C36	330 μ F, 63 V Electrolytic Capacitors	EMVY630GTR331MMH0S	Nippon Chemi-Con
Coax1, 2, 3, 4	25 Ω Semi Rigid Coax, 2.2" Long	UT-141C-25	Micro-Coax
L1, L2	2.5 nH, 1 Turn Inductors	A01TKLC	Coilcraft
L3, L4	43 nH, 10 Turn Inductors	B10TJLC	Coilcraft

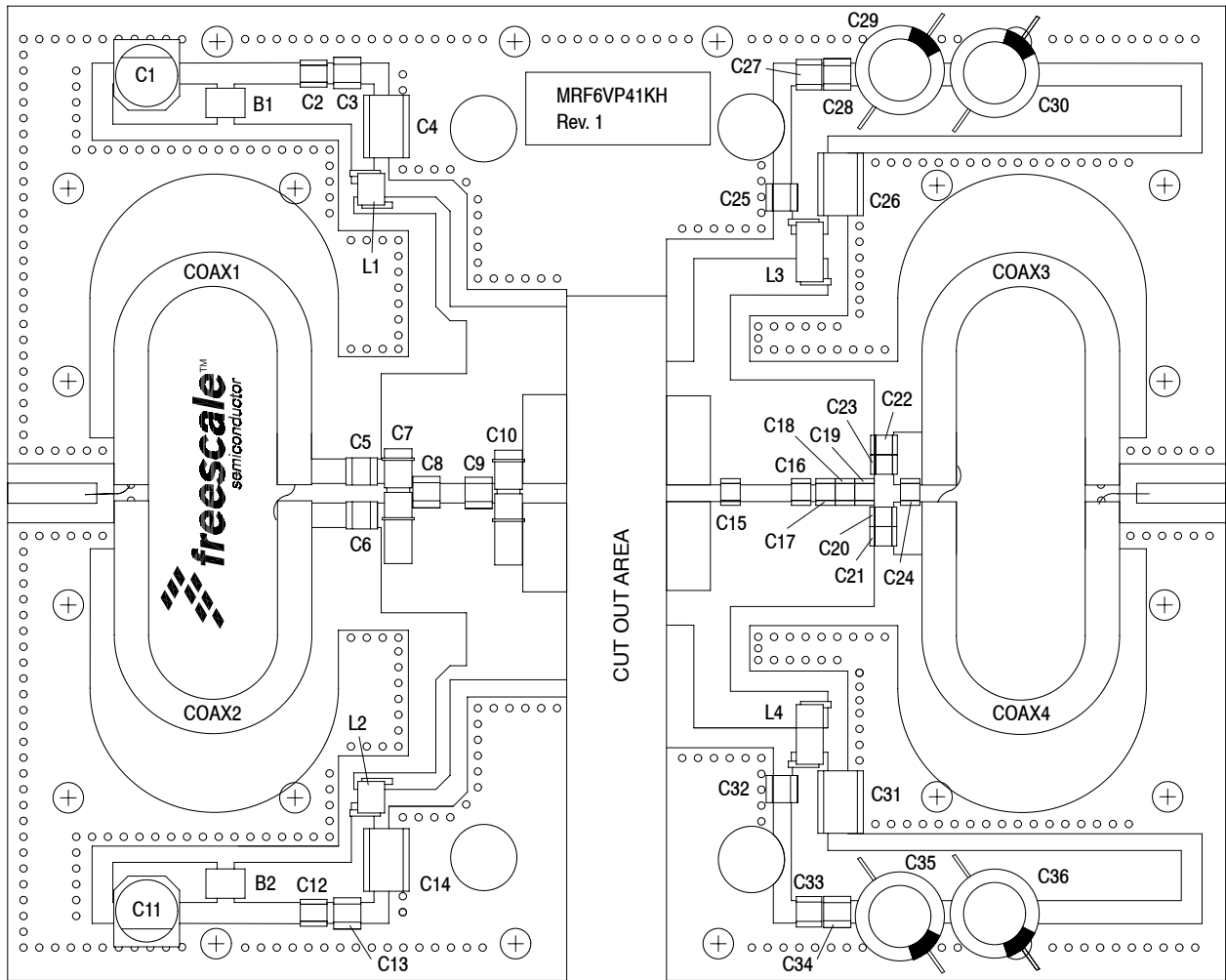
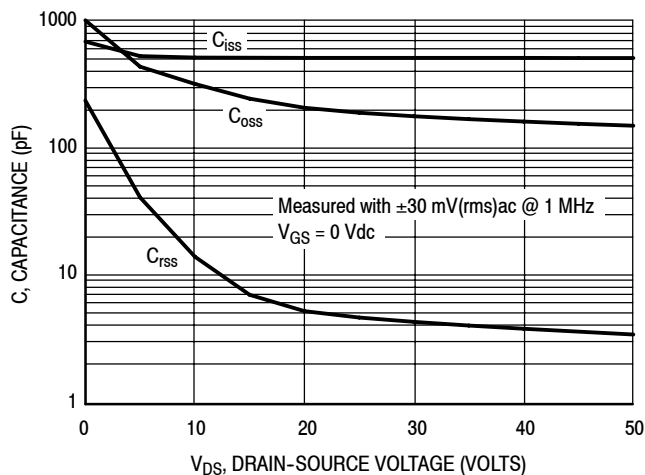

Figure 3. MRF6VP41KHR6(HSR6) Test Circuit Component Layout — 450 MHz

TYPICAL CHARACTERISTICS



Note: Each side of device measured separately.

Figure 4. Capacitance versus Drain-Source Voltage

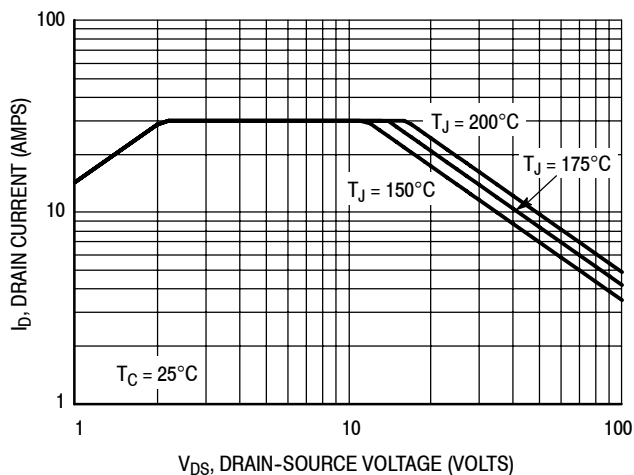

Note: Each side of device measured separately.

Figure 5. DC Safe Operating Area

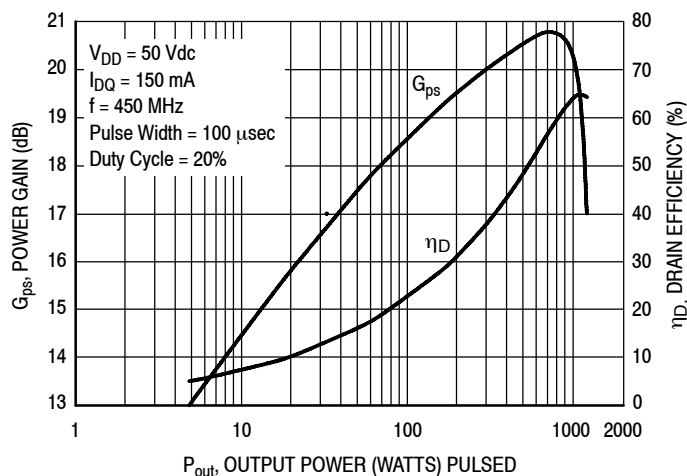

Figure 6. Pulsed Power Gain and Drain Efficiency versus Output Power

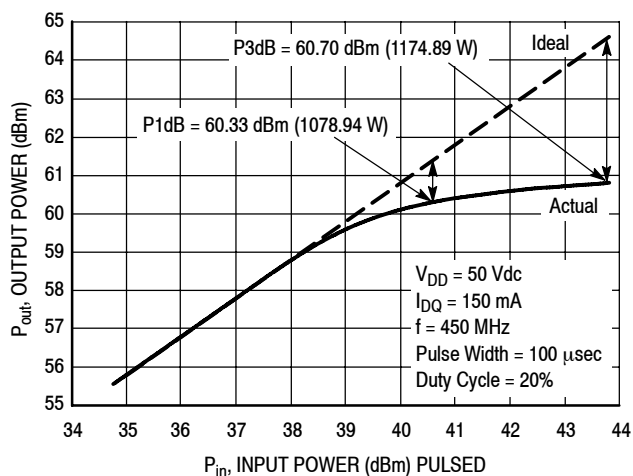

Figure 7. Pulsed Output Power versus Input Power

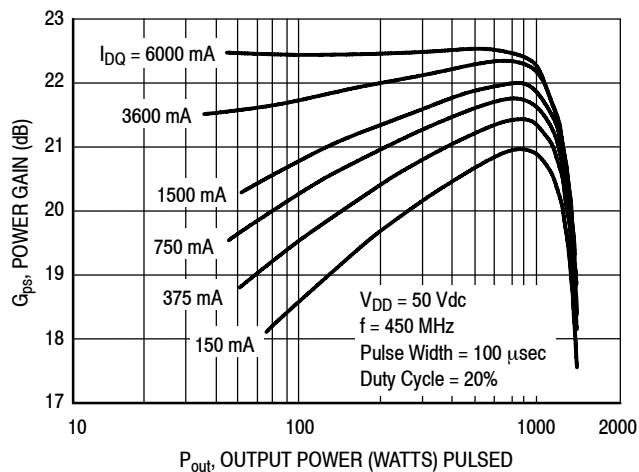

Figure 8. Pulsed Power Gain versus Output Power

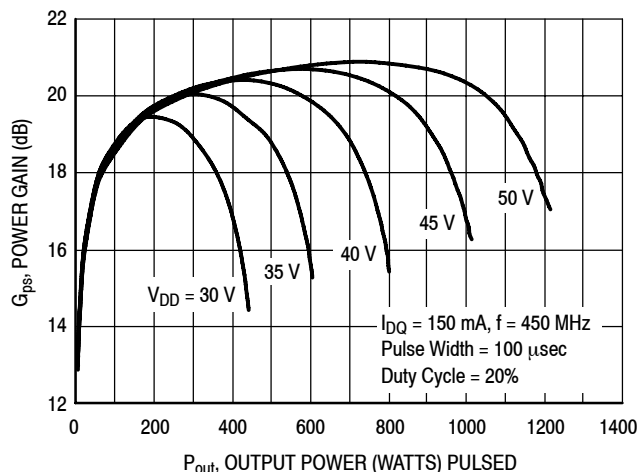

Figure 9. Pulsed Power Gain versus Output Power

TYPICAL CHARACTERISTICS

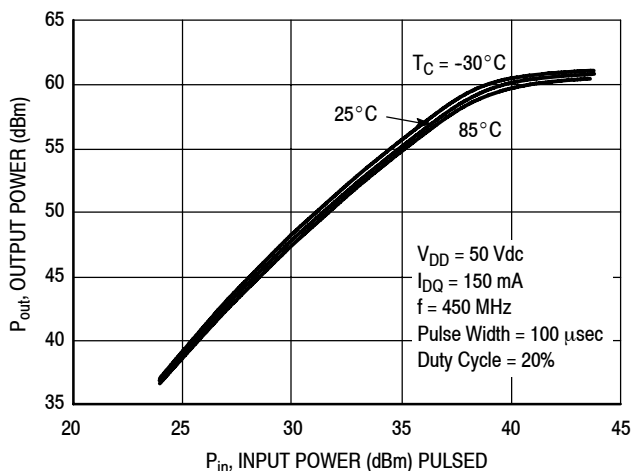

Figure 10. Pulsed Output Power versus Input Power

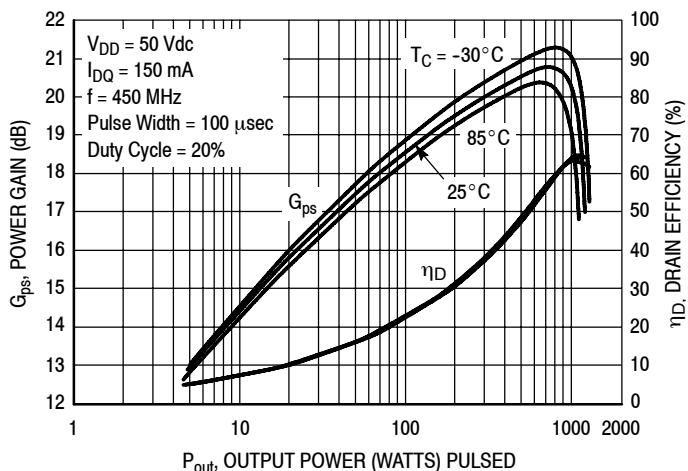

Figure 11. Pulsed Power Gain and Drain Efficiency versus Output Power

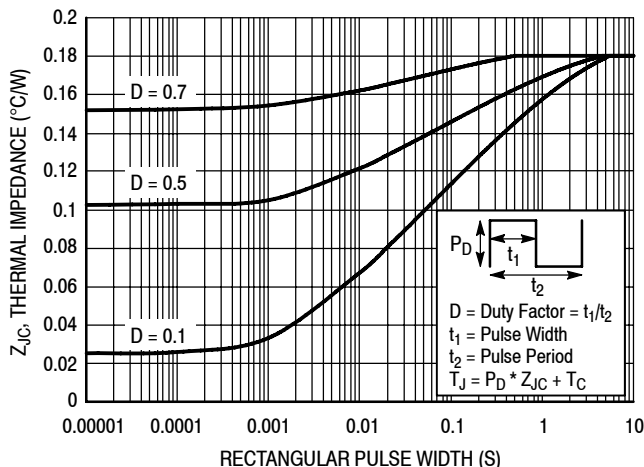
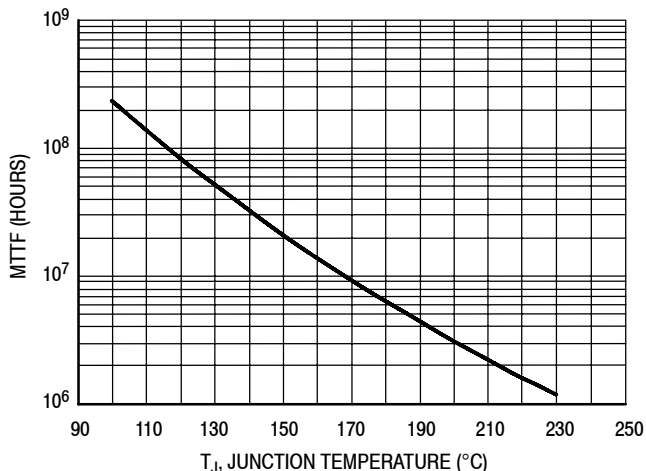

Figure 12. Maximum Transient Thermal Impedance



This above graph displays calculated MTTF in hours when the device is operated at $V_{DD} = 50$ Vdc, $P_{out} = 1000$ W Peak, Pulse Width = 100 μ sec, Duty Cycle = 20%, and $\eta_D = 64\%$.

MTTF calculator available at <http://www.freescale.com/rf>. Select Software & Tools/Development Tools/Calculators to access MTTF calculators by product.

Figure 13. MTTF versus Junction Temperature — Pulsed

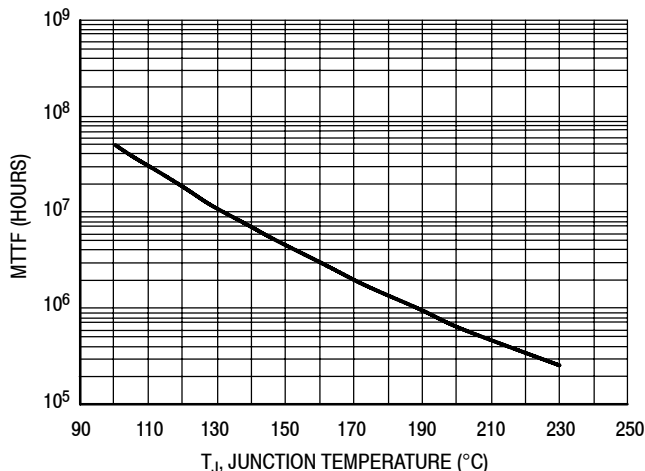

This above graph displays calculated MTTF in hours when the device is operated at $V_{DD} = 50$ Vdc, $P_{out} = 1000$ W CW, and $\eta_D = 67\%$.

MTTF calculator available at <http://www.freescale.com/rf>. Select Software & Tools/Development Tools/Calculators to access MTTF calculators by product.

Figure 14. MTTF versus Junction Temperature — CW

MRF6VP41KHR6 MRF6VP41KHSR6

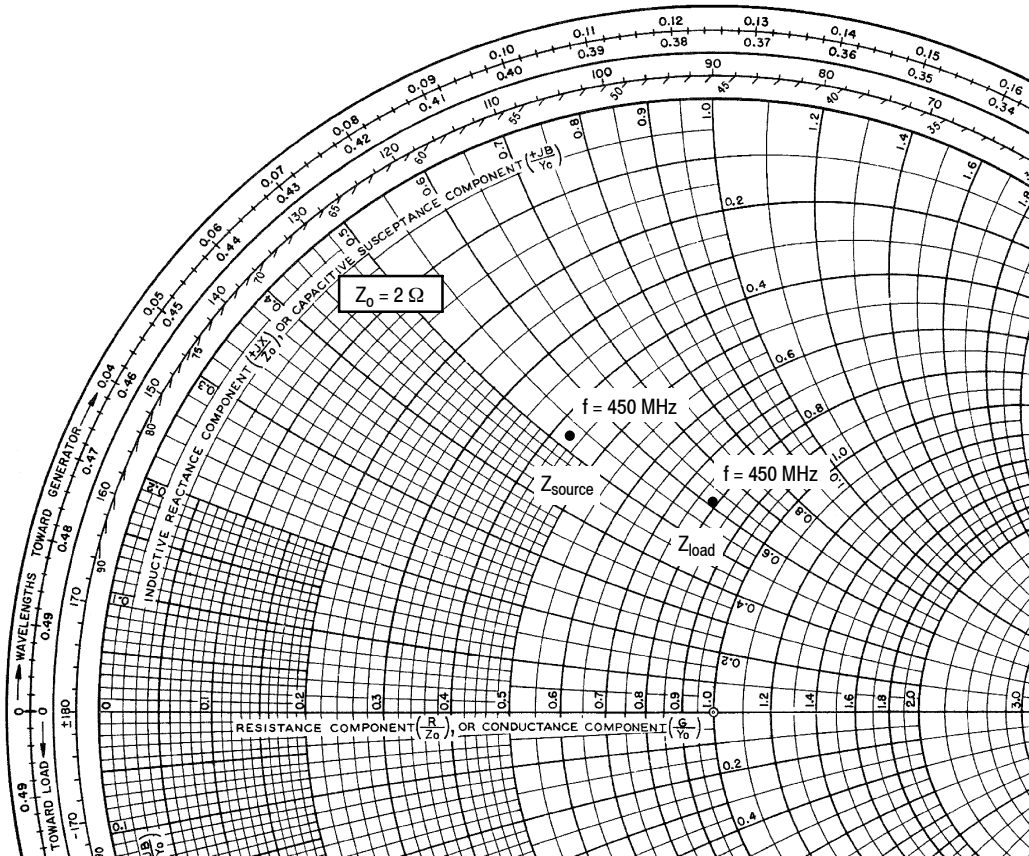

$V_{DD} = 50 \text{ Vdc}$, $I_{DQ} = 150 \text{ mA}$, $P_{out} = 1000 \text{ W Peak}$

f MHz	Z_{source} Ω	Z_{load} Ω
450	$0.86 + j1.06$	$1.58 + j1.22$

Z_{source} = Test circuit impedance as measured from gate to gate, balanced configuration.

Z_{load} = Test circuit impedance as measured from drain to drain, balanced configuration.

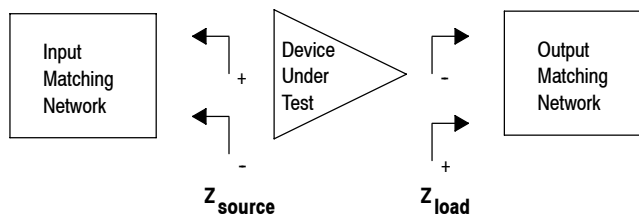

Figure 15. Series Equivalent Source and Load Impedance — 450 MHz

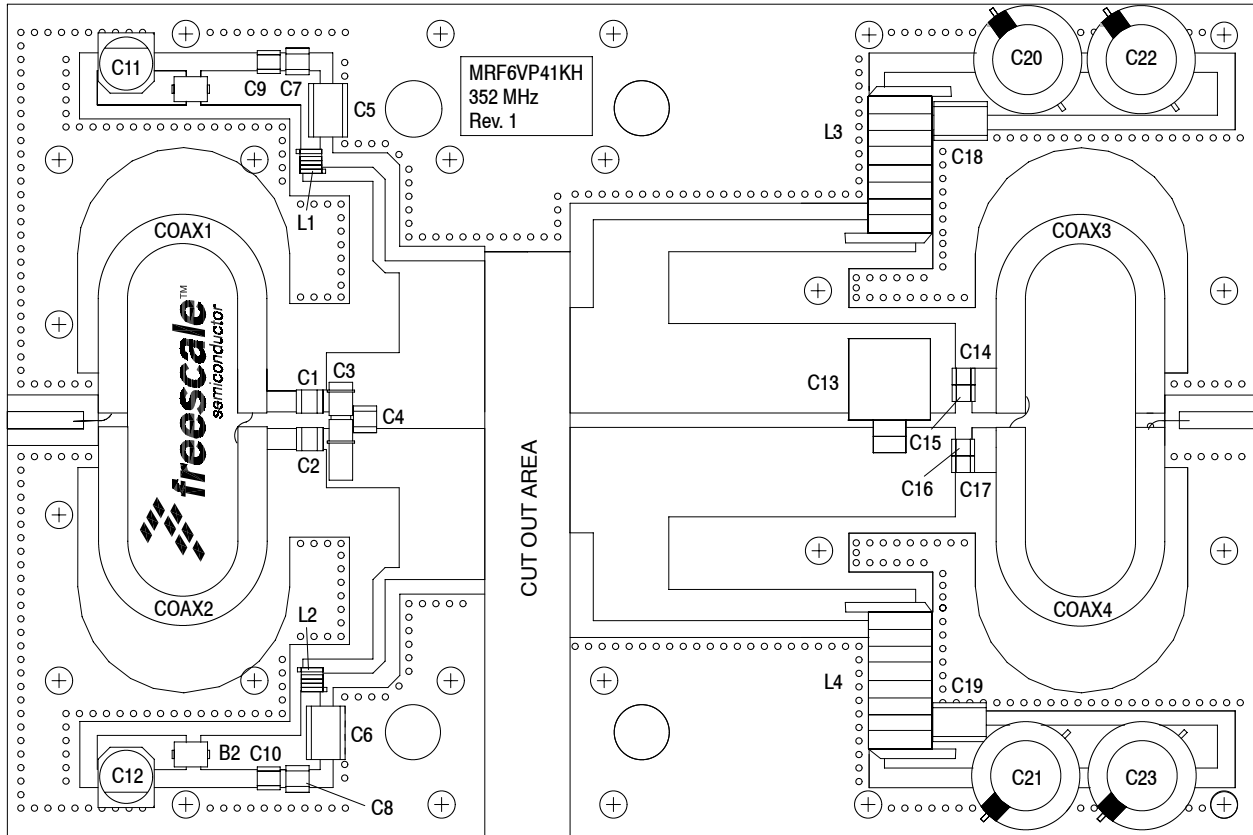
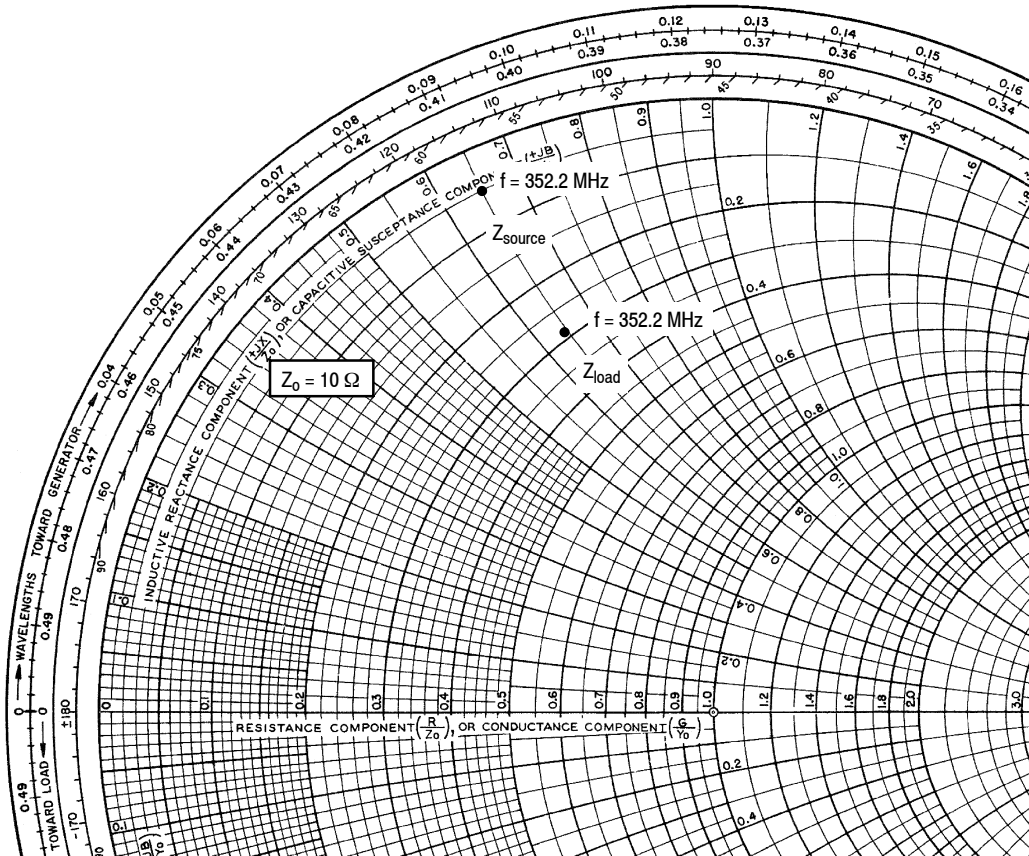

Figure 16. MRF6VP41KHR6(HSR6) Test Circuit Component Layout — 352.2 MHz

Table 6. MRF6VP41KHR6(HSR6) Test Circuit Component Designations and Values — 352.2 MHz

Part	Description	Part Number	Manufacturer
B1, B2	47 Ω , 100 MHz Short Ferrite Beads	2743019447	Fair-Rite
Coax1, 2, 3, 4	25 Ω Semi Rigid coax, 2.2" Long	UT141-25	Precision Tube Company
C1, C2	27 pF Chip Capacitors	ATC100B270JT500XT	ATC
C3	0.8–8.0 pF Variable Capacitor, Gigatrim	27291SL	Johanson
C4	75 pF Chip Capacitor	ATC100B750JT500XT	ATC
C5, C6	2.2 μ F Chip Capacitors	C1825C225J5RAC	Kemet
C7, C8	220 nF Chip Capacitors	C1812C224J5RAC	Kemet
C9, C10	0.1 μ F Chip Capacitors	CDR33BX104AKYS	AVX
C11, C12	47 μ F, 50 V Electrolytic Capacitors	476KXM050M	Illinois Cap
C13	36 pF 500 V Chip Capacitor	MCM01-009ED360J-F	CDE
C14, C15, C16, C17	240 pF Chip Capacitors	ATC100B241JT200XT	ATC
C18, C19	2.2 μ F Chip Capacitors	G2225X7R225KT3AB	ATC
C20, C21, C22, C23	470 μ F, 63 V Electrolytic Capacitors	MCRH63V477M13X21-RH	Multicomp
L1, L2	2.5 nH Inductors	A01T	Coilcraft
L3, L4	10 Turn #16 AWG ID=0.160" Inductors, Hand Wound	Copper Wire	Freescale
PCB	Arlon CuClad 250GX-0300-55-22, 0.030", $\epsilon_r = 2.55$	DS2655	DS Electronics



$V_{DD} = 50 \text{ Vdc}$, $I_{DQ} = 150 \text{ mA}$, $P_{out} = 1000 \text{ W CW}$

f MHz	Z_{source} Ω	Z_{load} Ω
352.2	$0.5 + j6.5$	$2.9 + j6.35$

Z_{source} = Test circuit impedance as measured from gate to gate, balanced configuration.

Z_{load} = Test circuit impedance as measured from drain to drain, balanced configuration.

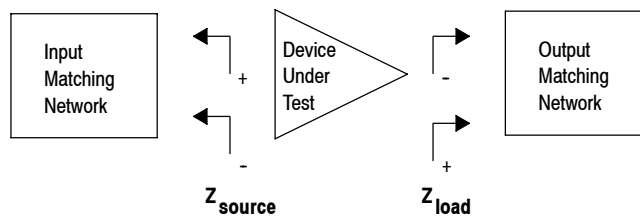
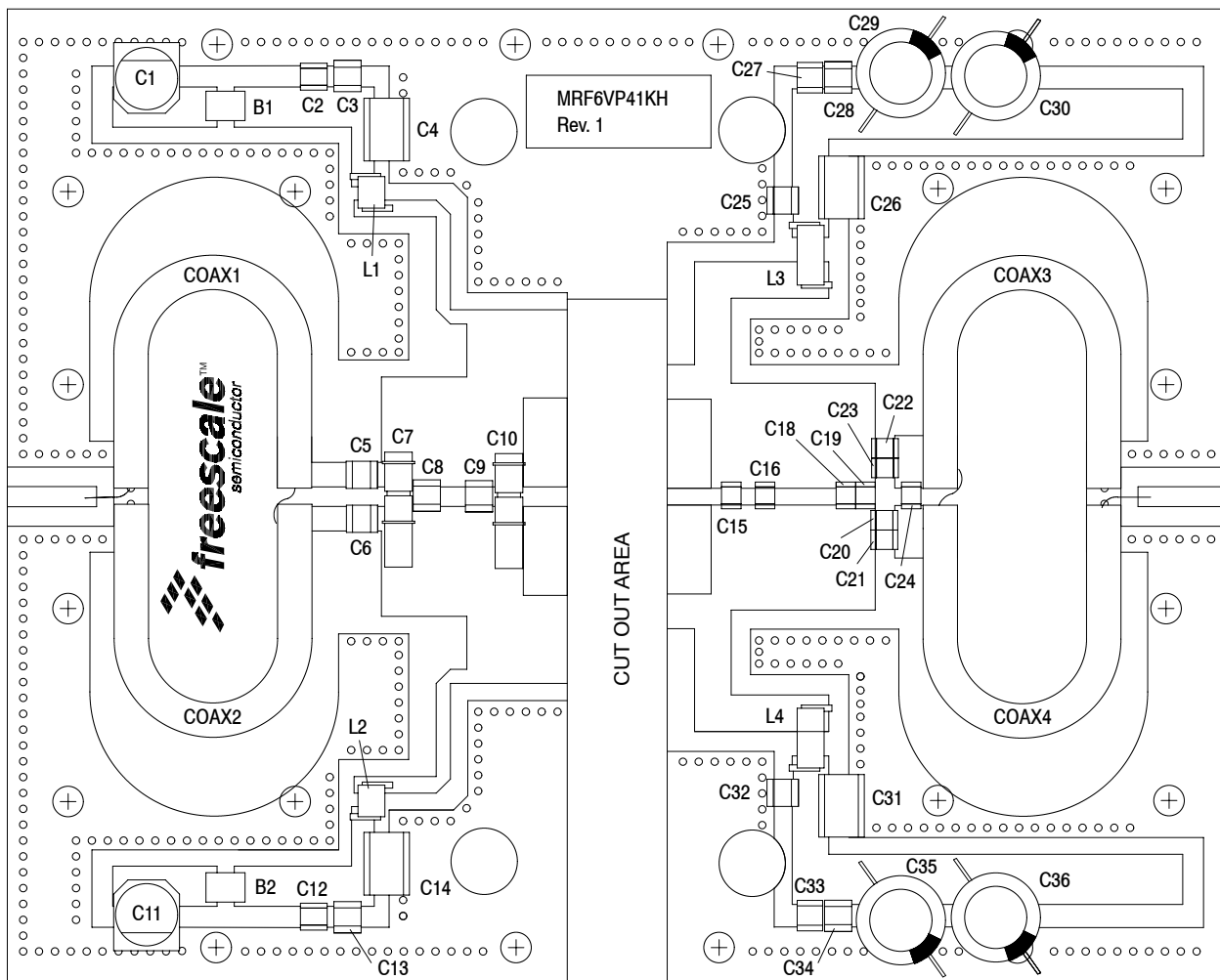

Figure 17. Series Equivalent Source and Load Impedance — 352.2 MHz



C17 not used in MRF6VP41KHR6(HSR6) 500 MHz application.

Figure 18. MRF6VP41KHR6(HSR6) Test Circuit Component Layout — 500 MHz

Table 7. MRF6VP41KHR6(HSR6) Test Circuit Component Designations and Values — 500 MHz

Part	Description	Part Number	Manufacturer
B1, B2	47 Ω , 100 MHz Short Ferrite Beads	2743019447	Fair-Rite
Coax1, 2, 3, 4	25 Ω Semi Rigid coax, 2.2" Long	UT-141C-25	Micro-Coax
C1, C11	47 μ F, 50 V Electrolytic Capacitors	476KXM063M	Illinois
C2, C12, C28, C34	0.1 μ F Chip Capacitors	CDR33BX104AKYS	Kemet
C3, C13, C27, C33	220 nF, 50 V Chip Capacitors	C1812C224K5RAC	Kemet
C4, C14	2.2 μ F, 50 V Chip Capacitors	C1825C225J5RAC	Kemet
C5, C6, C15	27 pF Chip Capacitors	ATC100B270JT500XT	ATC
C7, C10	0.8–8.0 pF Variable Capacitors	27291SL	Johanson Components
C9	33 pF Chip Capacitor	ATC100B330JT500XT	ATC
C8	13 pF Chip Capacitor	ATC100B120JT500XT	ATC
C18	9.1 pF Chip Capacitor	ATC100B9R1CT500XT	ATC
C19, C16	8.2 pF Chip Capacitors	ATC100B8R2CT500XT	ATC
C20, C21, C22, C23, C25, C32	240 pF Chip Capacitors	ATC100B241JT200XT	ATC
C24	5.6 pF Chip Capacitor	ATC100B5R6CT500XT	ATC
C26, C31	2.2 μ F, 100 V Chip Capacitors	2225X7R225KT3AB	ATC
C29, C30, C35, C36	330 μ F, 63 V Electrolytic Capacitors	MCRH63V337M13X21-RH	Multicomp
L1, L2	2.5 nH, 1 Turn Inductors	A01TKLC	Coilcraft
L3, L4	43 nH, 10 Turn Inductors	B10TJLC	Coilcraft

C17 not used in MRF6VP41KHR6(HSR6) 500 MHz application.

MRF6VP41KHR6 MRF6VP41KHSR6

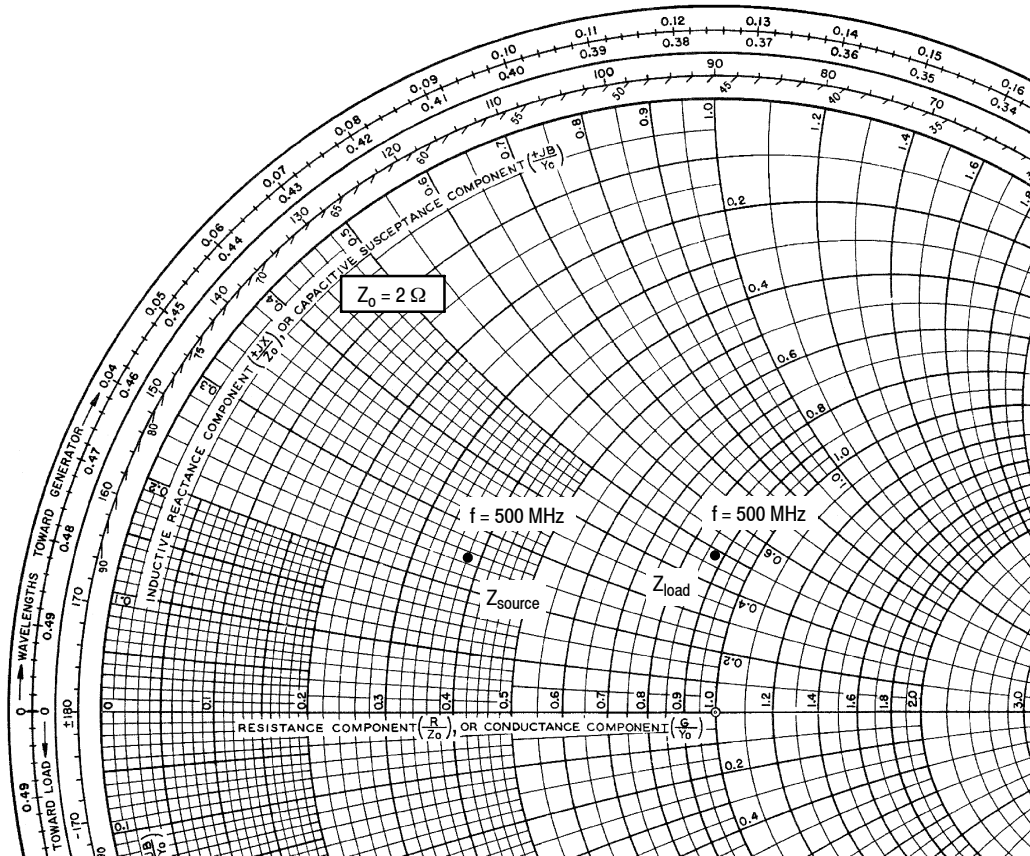

$V_{DD} = 50 \text{ Vdc}$, $I_{DQ} = 150 \text{ mA}$, $P_{out} = 1000 \text{ W Peak}$

f MHz	Z_{source} Ω	Z_{load} Ω
500	$0.75 + j0.5$	$1.73 + j0.95$

Z_{source} = Test circuit impedance as measured from gate to gate, balanced configuration.

Z_{load} = Test circuit impedance as measured from drain to drain, balanced configuration.

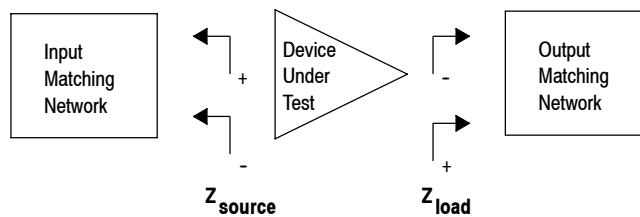
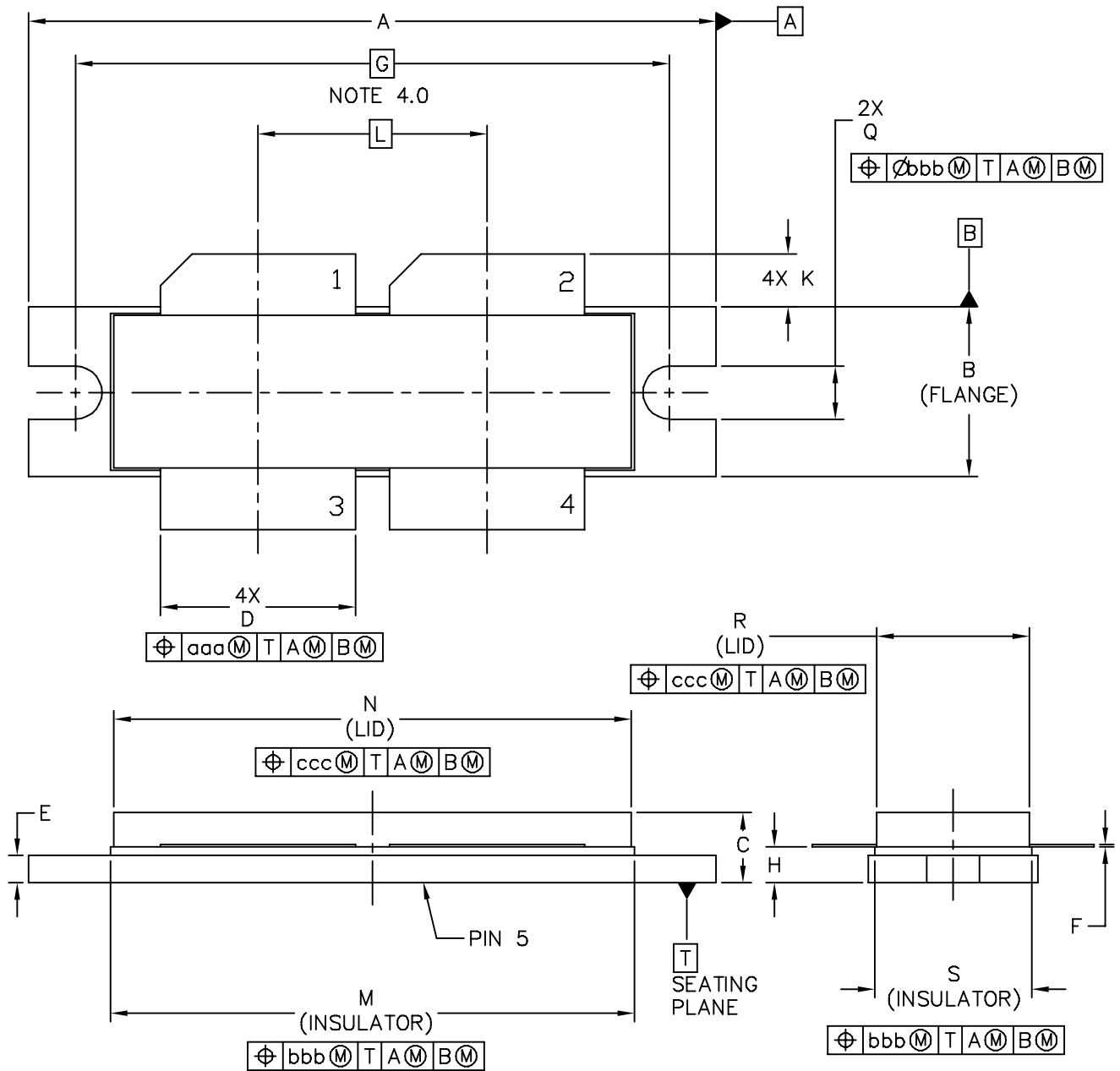

Figure 19. Series Equivalent Source and Load Impedance — 500 MHz

PACKAGE DIMENSIONS



© FREESCALE SEMICONDUCTOR, INC. ALL RIGHTS RESERVED.	MECHANICAL OUTLINE	PRINT VERSION NOT TO SCALE
TITLE: <div style="text-align: center; font-size: 1.2em;">NI-1230</div>	DOCUMENT NO: 98ASB16977C CASE NUMBER: 375D-05 STANDARD: NON-JEDEC	REV: E 31 MAR 2005

MRF6VP41KHR6 MRF6VP41KHSR6

NOTES:

- 1.0 INTERPRET DIMENSIONS AND TOLERANCES PER ASME Y14.5M-1994.
- 2.0 CONTROLLING DIMENSION: INCH
- 3.0 DIMENSION H IS MEASURED .030 (0.762) AWAY FROM PACKAGE BODY.
- 4.0 RECOMMENDED BOLT CENTER DIMENSION OF 1.52 (38.61) BASED ON M3 SCREW.

STYLE 1:

- PIN 1 - DRAIN
- 2 - DRAIN
- 3 - GATE
- 4 - GATE
- 5 - SOURCE

DIM	INCH		MILLIMETER		DIM	INCH		MILLIMETER	
	MIN	MAX	MIN	MAX		MIN	MAX	MIN	MAX
A	1.615	1.625	41.02	41.28	N	1.218	1.242	30.94	31.55
B	.395	.405	10.03	10.29	Q	.120	.130	3.05	3.3
C	.150	.200	3.81	5.08	R	.355	.365	9.01	9.27
D	.455	.465	11.56	11.81	S	.365	.375	9.27	9.53
E	.062	.066	1.57	1.68					
F	.004	.007	0.1	0.18					
G	1.400 BSC		35.56 BSC		aaa	.013		0.33	
H	.082	.090	2.08	2.29	bbb	.010		0.25	
K	.117	.137	2.97	3.48	ccc	.020		0.51	
L	.540 BSC		13.72 BSC						
M	1.219	1.241	30.96	31.52					

© FREESCALE SEMICONDUCTOR, INC. ALL RIGHTS RESERVED.		MECHANICAL OUTLINE		PRINT VERSION NOT TO SCALE	
TITLE: NI-1230		DOCUMENT NO: 98ASB16977C		REV: E	
		CASE NUMBER: 375D-05		31 MAR 2005	
		STANDARD: NON-JEDEC			

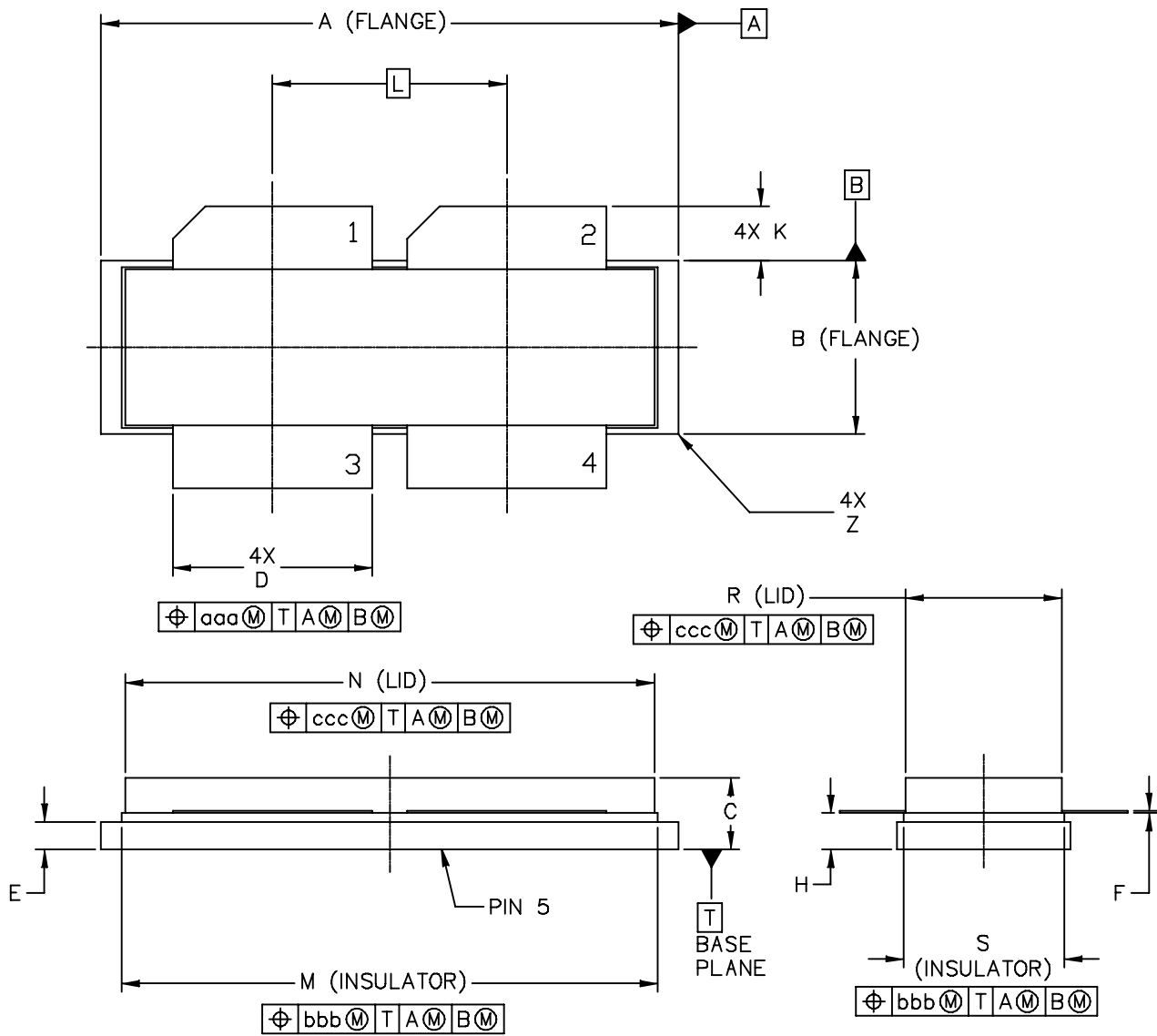

© FREESCALE SEMICONDUCTOR, INC. ALL RIGHTS RESERVED.	MECHANICAL OUTLINE	PRINT VERSION NOT TO SCALE	
TITLE: NI-1230S	DOCUMENT NO: 98ARB18247C	REV: F	
	CASE NUMBER: 375E-04	05 AUG 2005	
	STANDARD: NON-JEDEC		

NOTES:

1. INTERPRET DIMENSIONS AND TOLERANCES PER ASME Y14.5M-1994.
2. CONTROLLING DIMENSION: INCH
3. DIMENSION H IS MEASURED .030 AWAY FROM PACKAGE BODY

STYLE 1:

- PIN 1 - DRAIN
- 2 - DRAIN
- 3 - GATE
- 4 - GATE
- 5 - SOURCE

DIM	INCHES		MILLIMETERS		DIM	INCHES		MILLIMETERS	
	MIN	MAX	MIN	MAX		MIN	MAX	MIN	MAX
A	1.265	1.275	32.13	32.38	R	.355	.365	9.01	9.27
B	.395	.405	10.03	10.29	S	.365	.375	9.27	9.53
C	.150	.200	3.81	5.08	Z	---	.040	---	1.02
D	.455	.465	11.56	11.81					
E	.062	.066	1.57	1.68	aaa	.013		0.33	
F	.004	.007	0.1	0.18	bbb	.010		0.25	
H	.082	.090	2.08	2.29	ccc	.020		0.51	
K	.117	.137	2.97	3.48					
L	.540 BSC		13.72 BSC						
M	1.219	1.241	30.96	31.52					
N	1.218	1.242	30.94	31.55					
© FREESCALE SEMICONDUCTOR, INC. ALL RIGHTS RESERVED.			MECHANICAL OUTLINE			PRINT VERSION NOT TO SCALE			
TITLE: NI-1230S					DOCUMENT NO: 98ARB18247C			REV: F	
					CASE NUMBER: 375E-04			05 AUG 2005	
					STANDARD: NON-JEDEC				

PRODUCT DOCUMENTATION AND SOFTWARE

Refer to the following documents to aid your design process.

Application Notes

- AN1955: Thermal Measurement Methodology of RF Power Amplifiers

Engineering Bulletins

- EB212: Using Data Sheet Impedances for RF LDMOS Devices

Software

- Electromigration MTTF Calculator
- RF High Power Model

For Software, do a Part Number search at <http://www.freescale.com>, and select the “Part Number” link. Go to the Software & Tools tab on the part’s Product Summary page to download the respective tool.

REVISION HISTORY

The following table summarizes revisions to this document.

Revision	Date	Description
0	Jan. 2008	<ul style="list-style-type: none"> • Initial Release of Data Sheet
1	Apr. 2008	<ul style="list-style-type: none"> • Added Fig. 12, Maximum Transient Thermal Impedance, p. 6
2	Sept. 2008	<ul style="list-style-type: none"> • Added Note to Fig. 4, Capacitance versus Drain-Source Voltage, to denote that each side of device is measured separately, p. 5 • Updated Fig. 5, DC Safe Operating Area, to clarify that measurement is on a per-side basis, p. 5 • Corrected Fig. 13, MTTF versus Junction Temperature, to reflect the correct die size and increased the MTTF factor accordingly, p. 6
3	Nov. 2008	<ul style="list-style-type: none"> • Added CW operation capability bullet to Features section, p. 1 • Added CW operation to Maximum Ratings table, p. 1 • Added CW thermal data to Thermal Characteristics table, p. 2 • Fig. 14, Series Equivalent Source and Load Impedance, corrected Z_{source} copy to read “Test circuit impedance as measured from gate to gate, balanced configuration” and Z_{load} copy to read “Test circuit impedance as measured from drain to drain, balanced configuration”; replaced impedance diagram to show push-pull test conditions, p. 7
4	Mar. 2009	<ul style="list-style-type: none"> • CW rating limits updated from 1176 W to 1107 W and 5.5 W/°C to 4.6 W/°C to reflect recent remeasured data, Max Ratings table, p. 1 • CW Thermal Characteristics changed from 81°C to 48°C and 0.16 °C/W to 0.15 °C/W using data from the most recent 352.2 MHz CW application circuit, p. 2 • Added Typical Performances table for 352.2 MHz and 500 MHz applications, p. 3 • Added Fig. 14, MTTF versus Junction Temperature - CW, p. 7 • Added Figs. 16 and 18, Test Circuit Component Layout - 352.2 MHz and 500 MHz, and Tables 6 and 7, Test Circuit Component Designations and Values - 352.2 MHz and 500 MHz, p. 9, 11 • Added Figs. 17 and 19, Series Equivalent Source and Load Impedance - 352.2 MHz and 500 MHz, p. 10, 12
5	Apr. 2010	<ul style="list-style-type: none"> • Operating Junction Temperature increased from 200°C to 225°C in Maximum Ratings table and related “Continuous use at maximum temperature will affect MTTF” footnote added, p. 1 • Added Electromigration MTTF Calculator and RF High Power Model availability to Product Software, p. 17

How to Reach Us:

Home Page:

www.freescale.com

Web Support:

<http://www.freescale.com/support>

USA/Europe or Locations Not Listed:

Freescale Semiconductor, Inc.
Technical Information Center, EL516
2100 East Elliot Road
Tempe, Arizona 85284
1-800-521-6274 or +1-480-768-2130
www.freescale.com/support

Europe, Middle East, and Africa:

Freescale Halbleiter Deutschland GmbH
Technical Information Center
Schatzbogen 7
81829 Muenchen, Germany
+44 1296 380 456 (English)
+46 8 52200080 (English)
+49 89 92103 559 (German)
+33 1 69 35 48 48 (French)
www.freescale.com/support

Japan:

Freescale Semiconductor Japan Ltd.
Headquarters
ARCO Tower 15F
1-8-1, Shimo-Meguro, Meguro-ku,
Tokyo 153-0064
Japan
0120 191014 or +81 3 5437 9125
support.japan@freescale.com

Asia/Pacific:

Freescale Semiconductor China Ltd.
Exchange Building 23F
No. 118 Jianguo Road
Chaoyang District
Beijing 100022
China
+86 10 5879 8000
support.asia@freescale.com

For Literature Requests Only:

Freescale Semiconductor Literature Distribution Center
1-800-441-2447 or +1-303-675-2140
Fax: +1-303-675-2150
LDCForFreescaleSemiconductor@hibbertgroup.com

Information in this document is provided solely to enable system and software implementers to use Freescale Semiconductor products. There are no express or implied copyright licenses granted hereunder to design or fabricate any integrated circuits or integrated circuits based on the information in this document.

Freescale Semiconductor reserves the right to make changes without further notice to any products herein. Freescale Semiconductor makes no warranty, representation or guarantee regarding the suitability of its products for any particular purpose, nor does Freescale Semiconductor assume any liability arising out of the application or use of any product or circuit, and specifically disclaims any and all liability, including without limitation consequential or incidental damages. "Typical" parameters that may be provided in Freescale Semiconductor data sheets and/or specifications can and do vary in different applications and actual performance may vary over time. All operating parameters, including "Typicals", must be validated for each customer application by customer's technical experts. Freescale Semiconductor does not convey any license under its patent rights nor the rights of others. Freescale Semiconductor products are not designed, intended, or authorized for use as components in systems intended for surgical implant into the body, or other applications intended to support or sustain life, or for any other application in which the failure of the Freescale Semiconductor product could create a situation where personal injury or death may occur. Should Buyer purchase or use Freescale Semiconductor products for any such unintended or unauthorized application, Buyer shall indemnify and hold Freescale Semiconductor and its officers, employees, subsidiaries, affiliates, and distributors harmless against all claims, costs, damages, and expenses, and reasonable attorney fees arising out of, directly or indirectly, any claim of personal injury or death associated with such unintended or unauthorized use, even if such claim alleges that Freescale Semiconductor was negligent regarding the design or manufacture of the part.

Freescale™ and the Freescale logo are trademarks of Freescale Semiconductor, Inc. All other product or service names are the property of their respective owners.

© Freescale Semiconductor, Inc. 2008-2010. All rights reserved.