

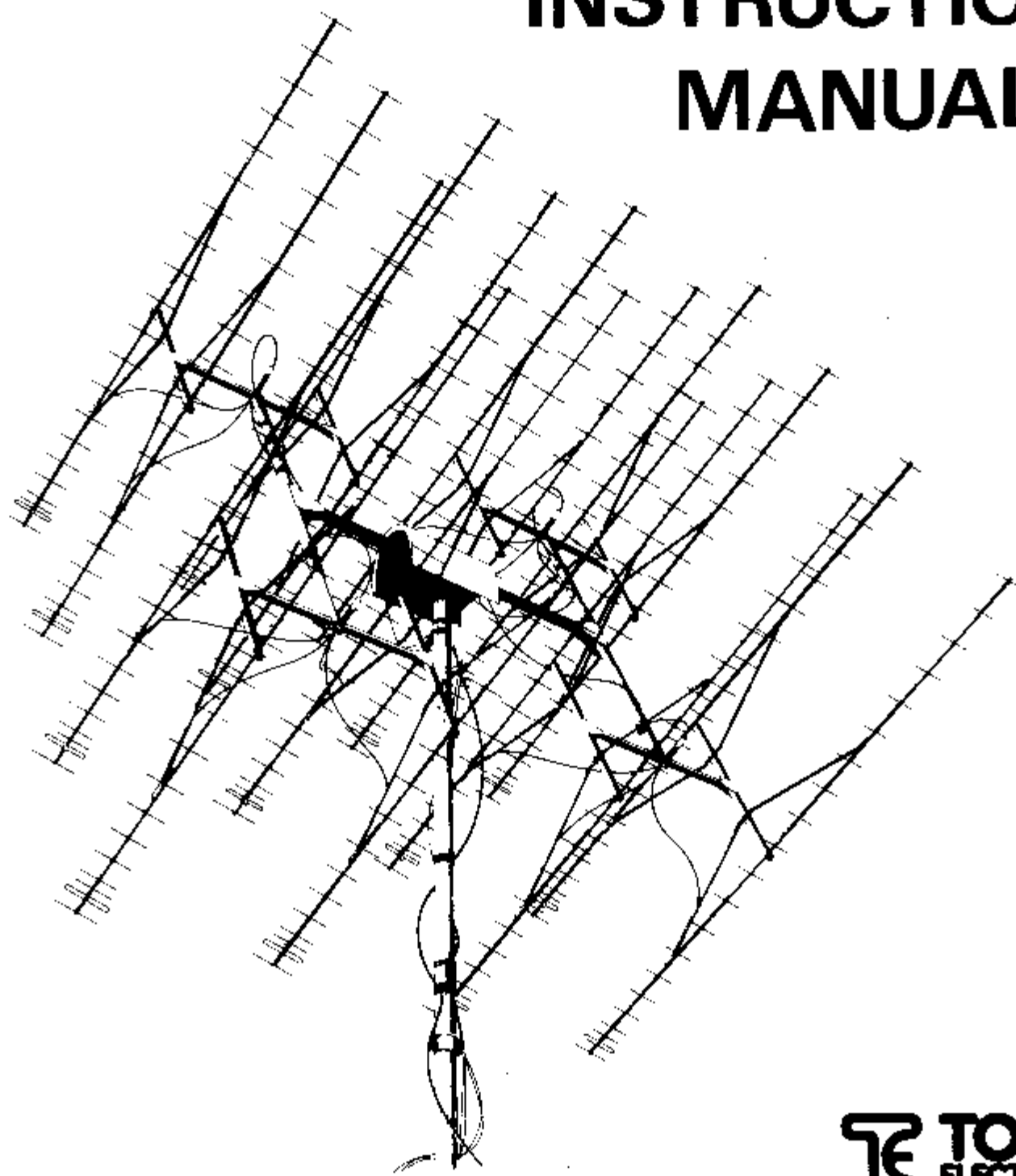

ANTENNES
TONNA







**144 MHz 9 ELEMENT
INSTRUCTION
MANUAL**



20809/A

TE TONNA
ELECTRONIQUE

PRESSE ETOUPE SYSTEME BERLOCK

-  Thick teflon bead
-  Pin
-  Thin teflon bead
-  Sleeve
-  Rubber joint
-  Nut

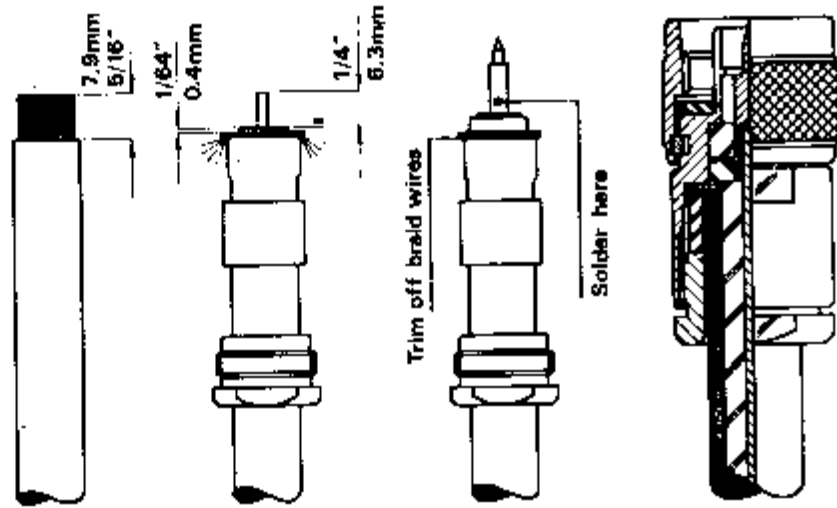

ANTENNE 9 ou 2x9 ELEMENTS YAGI: BANDE 144 - 146 MHz

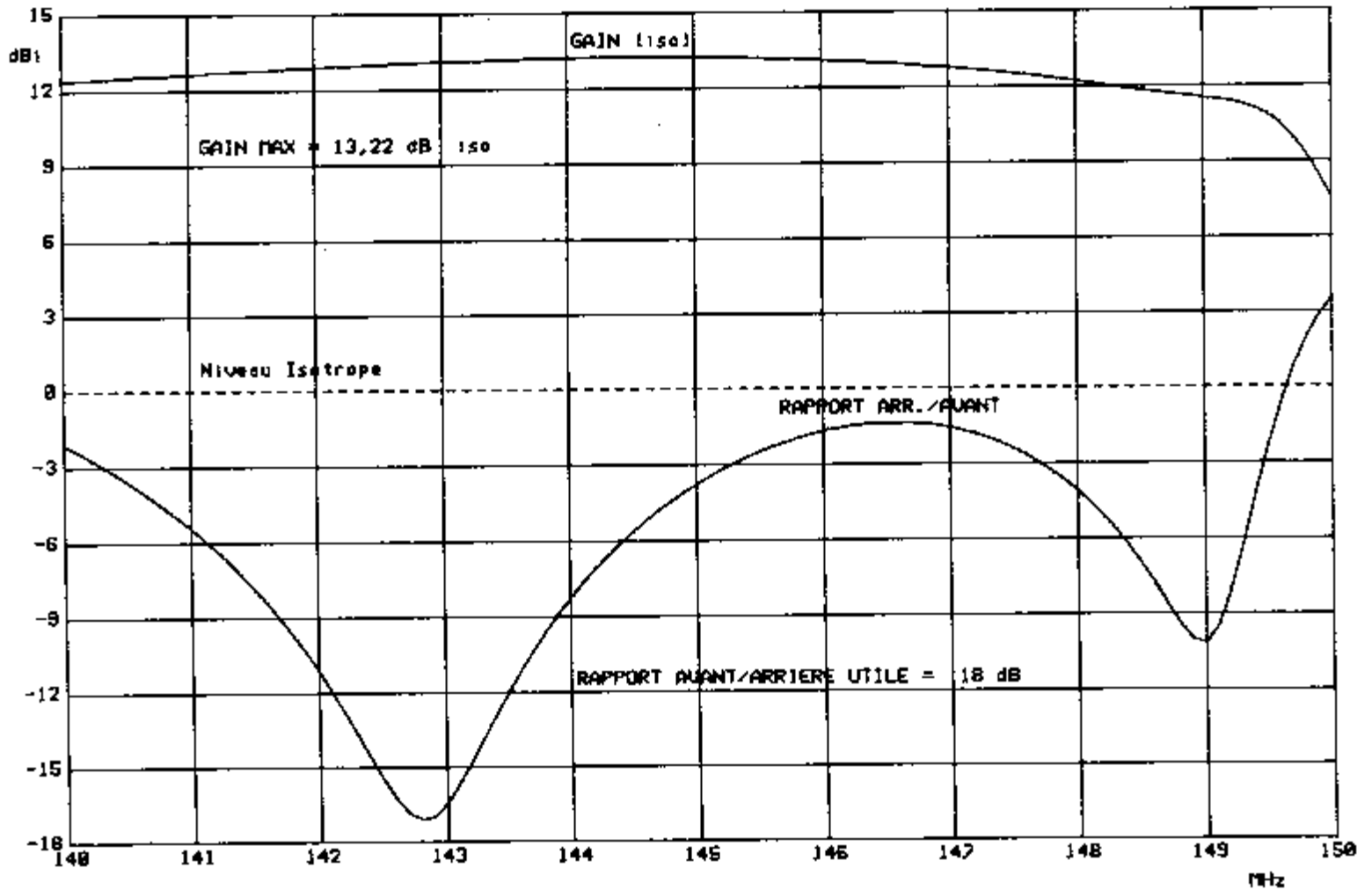

ASSEMBLY INSTRUCTIONS

144 MHz 9 element 99FT ANTENNA

IMPORTANT

When opening the package, check and compare all parts and hardware with enclosed part list. Then, thoroughly and carefully read the instructions.

ELEMENT ASSEMBLY

Each element is mounted on the boom with a special holder (#6 on diagram), made of glass fiber loaded polycarbonate. This holder is provided with a conical hole, into which a thread is forced with a special self tapping screw (#5 on diagram). DO NOT OVERTIGHTEN THIS SCREW !!

On each element is provided a centering bump which must fit inside the centering cavity of the holder (See arrow on medalion A). First snap the holder on the element, taking care for proper centering, and mount the holder on the boom, with screw #5. The holder should be mounted as shown on the diagram (the hole is located BEHIND the element, when antenna is seen from rear). If not, spacings between directors, driven elements and reflectors may not be correct any longer.

CAUTION

The antenna still being on the ground, make sure that all element lengths decrease, from reflector R (longer element) through director D7 (shorter element): each successive element set is either the same or shorter than the prior element. If not, performance of the antenna may be drastically reduced.

FEED-LINE AND DRIVEN ELEMENT

The feed-line is connected to the driven element (DIP) with a watertight type N connector set. The driven element is fitted with a built-in standard UG58A/U female receptacle. A standard UG21B/U male connector is delivered as accessory with the antenna. Use RG213/U, or better coaxial cable whenever available.

A quarter wave filter, called "bazooka" (#8), is used to cancel the outer currents on the outer conductor of the coaxial line. A plastic hood (#9) is also provided, to avoid condensation around the connector, on the driven element.

Slide the hood on the bazooka, the broad end of the hood facing to the free end of the bazooka; slide the bazooka on the coax, with the mounting clamp (#7) opposite to the coax end; mount the connector on the coax cable (See connector sketch for proper mounting on cable). Put the driven element case above mounting hole, and tighten with the wing screw #5. Screw in the UG21B/U connector on the UG58A/U receptacle, and finally tighten to boom the bazooka clamp, with M5 wing screw #16. DO NOT OVERTIGHTEN THE SCREWS! Slide the hood around the ring provided around the coaxial receptacle, on the driven element (See medalion B1 and B2), and drill a "breathing" hole (1.5 mm or 1/16 ") on the lower part of the hood.

Coaxial cable must run on the same side as the elements, "above" the element holders, taping occuring two or three times along the rear boom section.

BOOM ASSEMBLY

Set the mast to boom mounting bracket to match 20 millimeter square tubing: introduce tightening plate #11 into the proper slot (farther away from right angle bend), on plate #12. Screw in the M5 wing screws #15 to attach plate #11 to bracket main plate #12. Keep the assembly loose enough to allow boom sections to slide into the gap between plates #12 and #11. Introduce the two boom sections through each end of the bracket, so that they get in tight contact in the middle of the gap; then firmly tighten the two screws #15.

20809/A

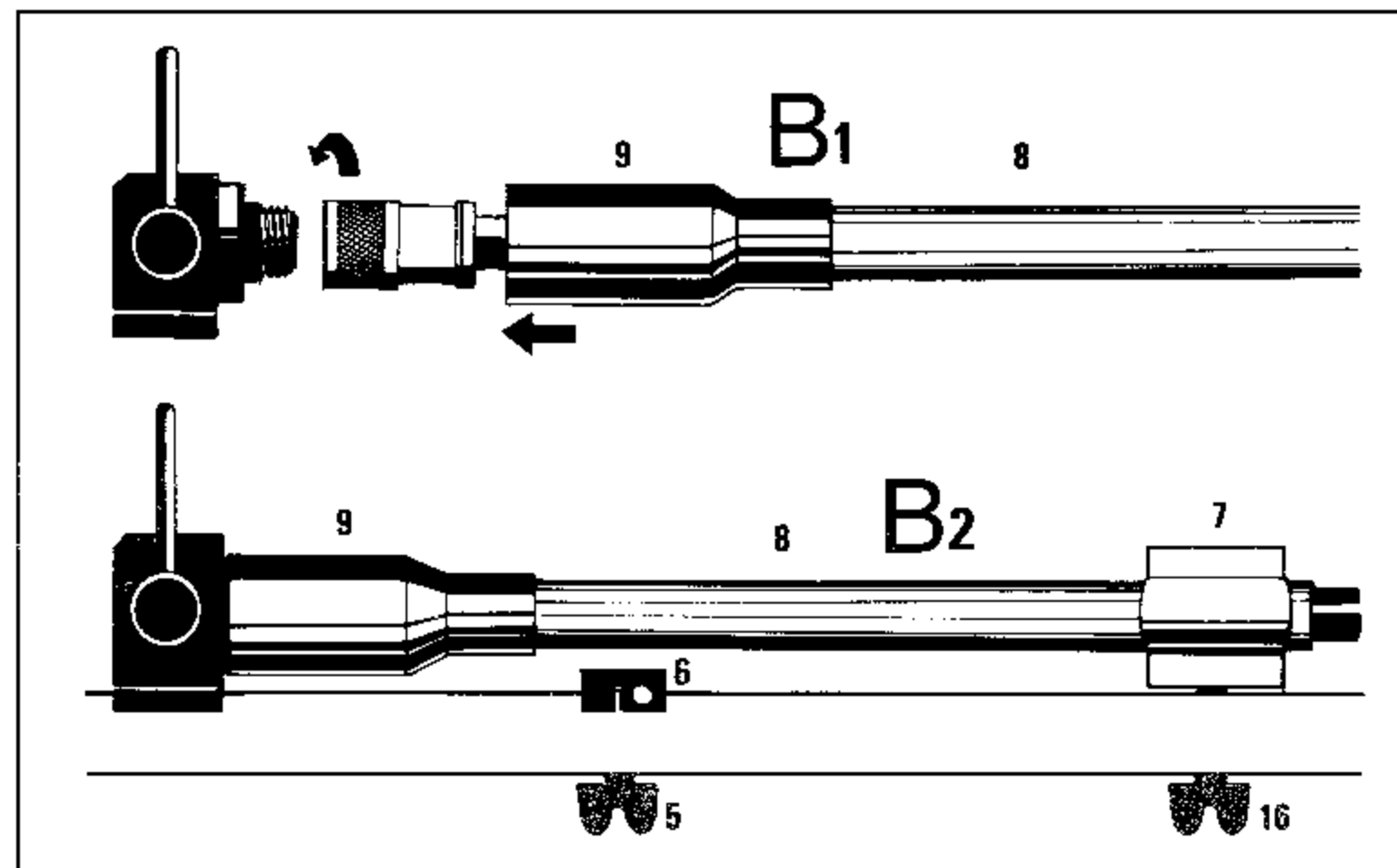
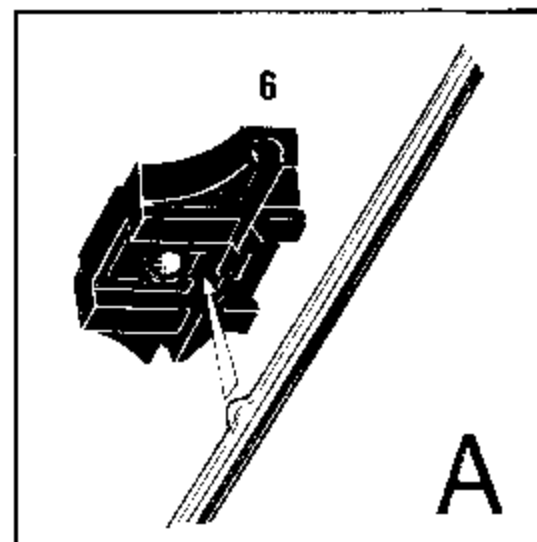
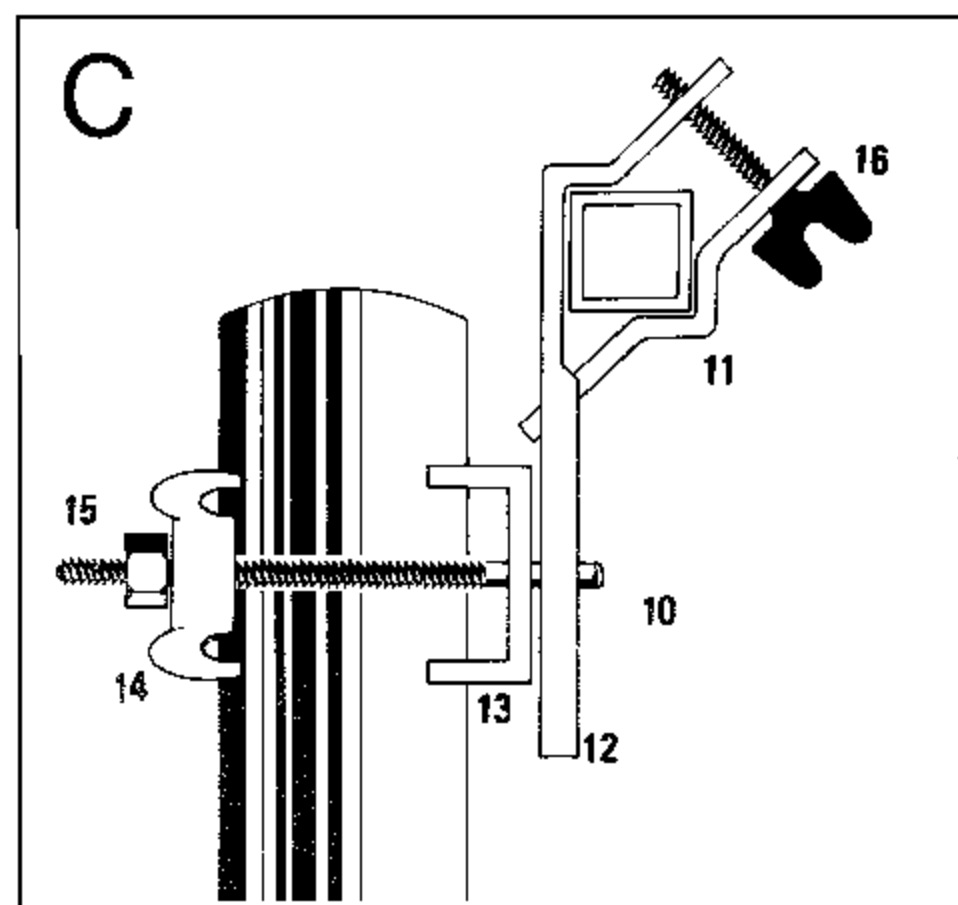
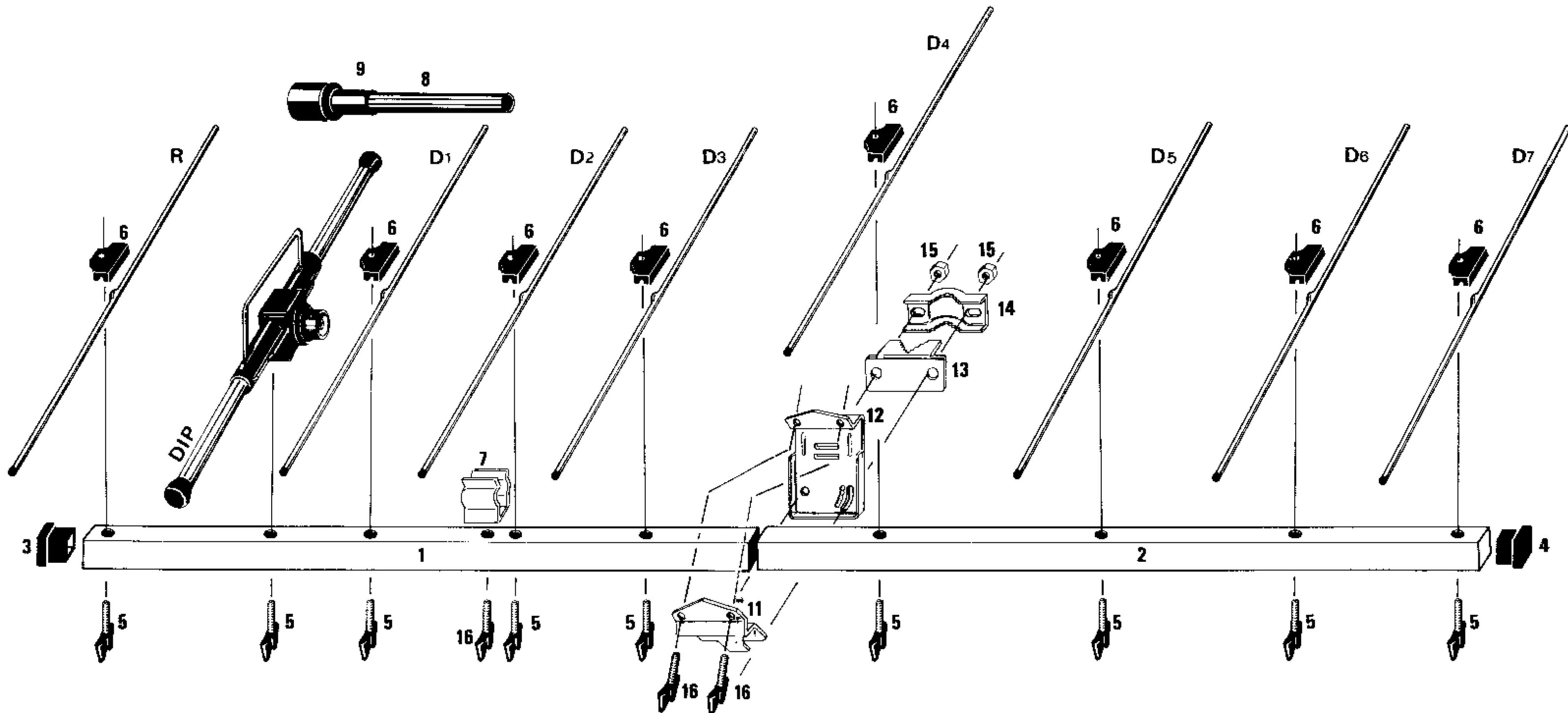

MOUNTING OF ANTENNA TO MAST

The maximum useful mast outer diameter is 54 millimeters (2" 1/8). Loosely mount U-bolt #10, clamps #13 and #14, and M6 nuts #15. Run mast through clamp set, and tighten boom to mast (see medalion C).

OPERATING HINTS

It is recommended to keep the antenna in local dominant wind direction, when not in use.

PART AND HARDWARE LIST

Diagram #	Description	Quantity
1	Rear boom section	1
2	Front boom section	1
3	Black cap (rear indicator)	1
4	Red cap (front indicator)	1
5	Special self tapping screw	9
6	Polycarbonate element holder	8
7	"Bazooka" mounting clamp	1
8	"Bazooka" (quarter wave filter)	1
9	Plastic hood	1
10	Stainless steel U-bolt M6x80	1
11	Boom size matching and tightening plate	1
12	Bracket main plate	1
13	Mast mounting "alligator" clamp	1
14	Mast tightening "alligator" clamp	1
15	Stainless steel tightening nut, M6	2
16	Stainless steel M5x25 wing screw	3

ACCESSORY

TYPE "N" MALE CONNECTOR UG21B/U	1
---------------------------------	---

ELEMENT LENGTHS

Element	Millimeters	Inches
Reflector	1030	40" 9/16
Diriv. el. *	* 970	* 38" 3/16
Director 1	984	38" 3/4
Director 2	957	37" 11/16
Director 3	945	37" 7/32
Director 4	930	36" 5/8
Director 5	920	36" 7/32
Director 6	910	35" 13/16
Director 7	900	35" 7/16

* Length without caps.

NOTE: The company ANTENNES TONNA S.A. reserves for itself the right for modifying its products, without notice.

20809/A

ANTENNES TONNA S.A. 132 Boulevard Dauphinot 51100 REIMS FRANCE

DIAGRAMME DE RAYONNEMENT CALCULE: ANTENNE 9 ELEMENTS YAGI

FREQUENCE: 144.0 MHz PLAN: E

GAIN CALCULE : 13.20 dB iso RAPPORT AU./ARR. : 21.50 dB

ANGLE D'OUVERTURE A -3dB : 2 x 19.49 deg.

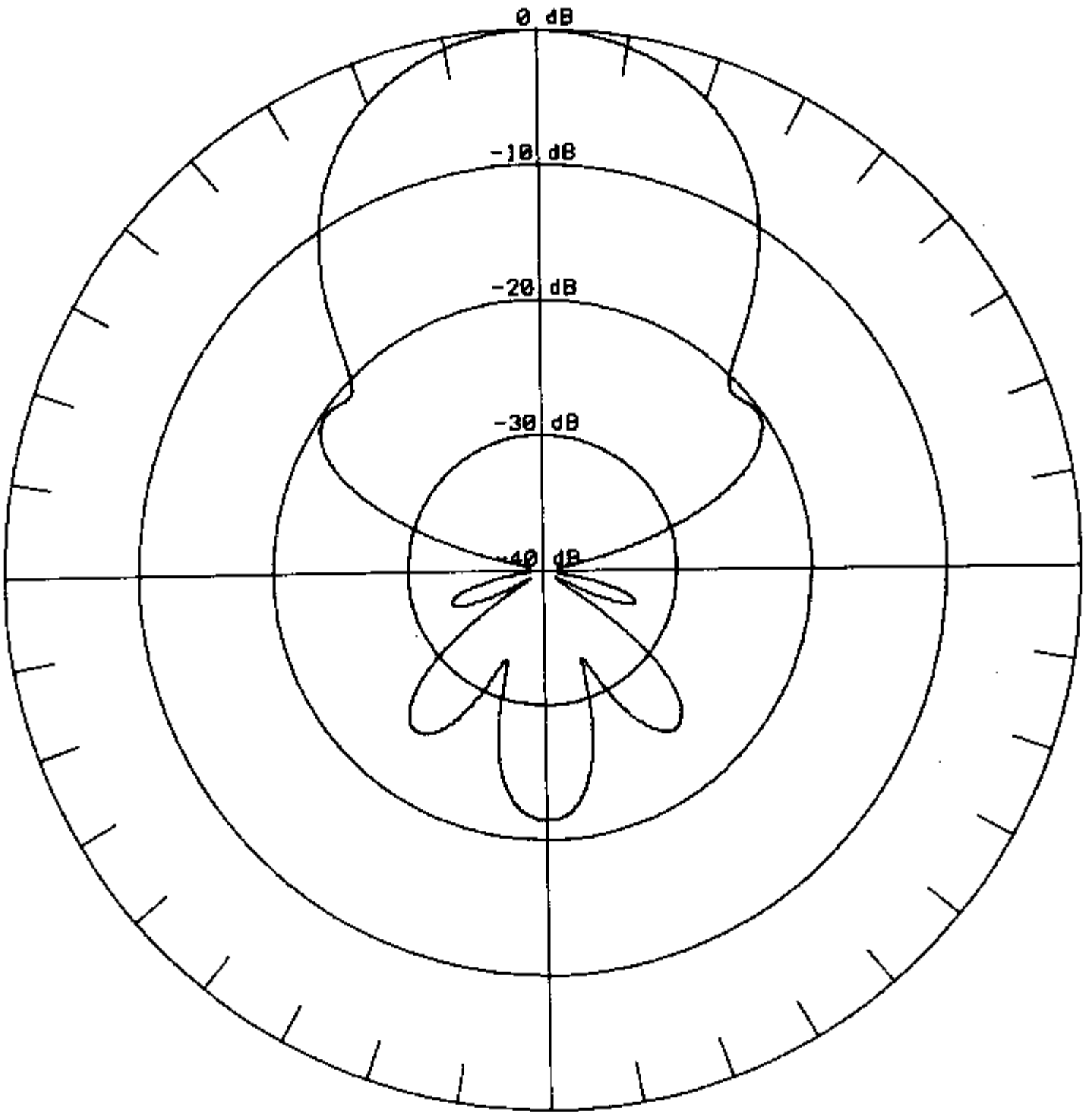

ANTENNES TONNA S.A. 132 Boulevard Dauphino 51100 REIMS FRANCE

DIAGRAMME DE RAYONNEMENT CALCULE: ANTENNE 9 ELEMENTS YAGI

FREQUENCE: 144.0 MHz PLAN: H

GAIN CALCULE : 13.20 dB iso RAPPORT AV./ARR. : 21.50 dB

ANGLE D'OUVERTURE A -3dB : 2 x 22.16 deg.

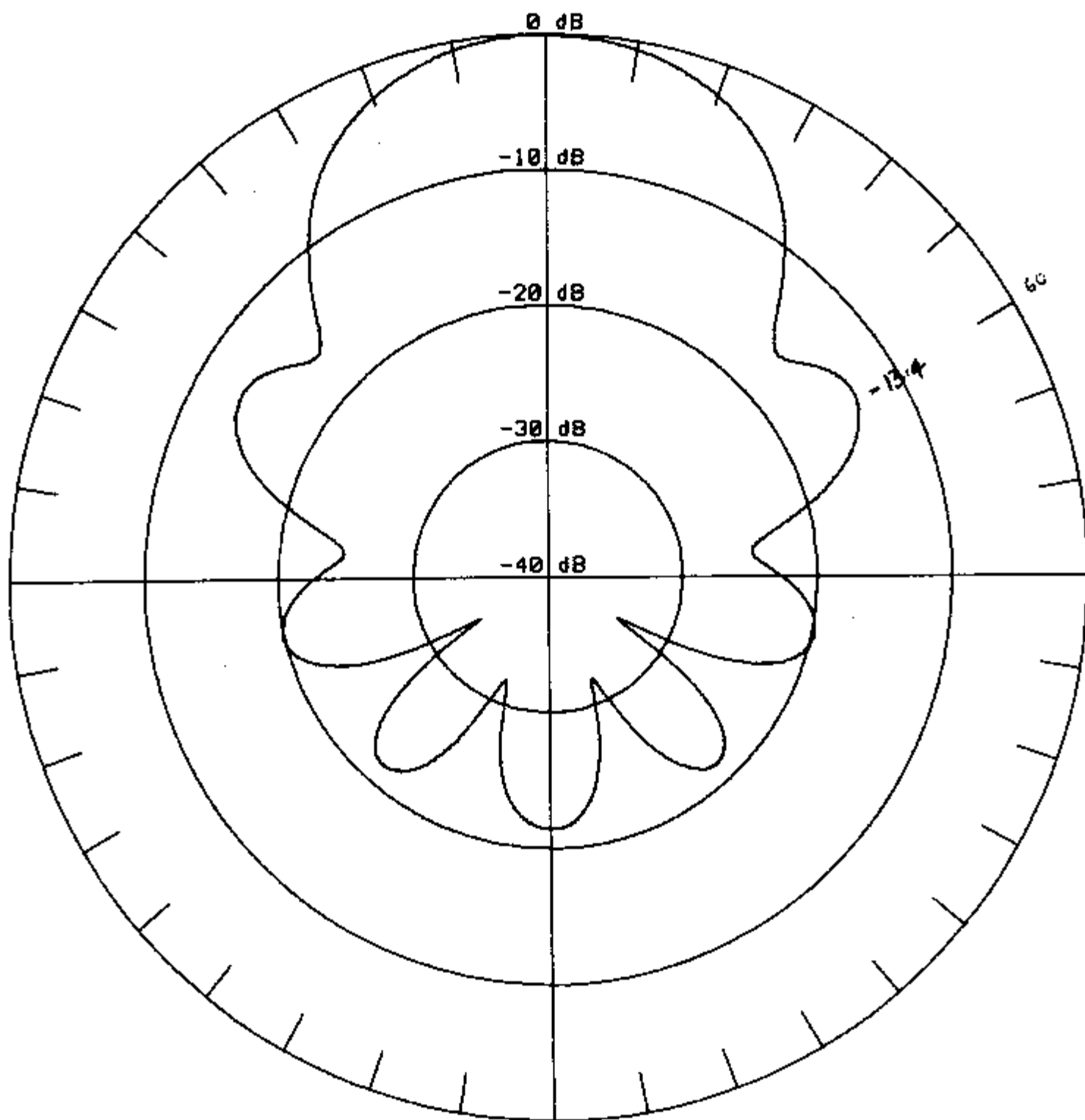

20809/A